

DINEX® ROBINET TOURNANT SPHERIQUE

3 PIECES
PASSAGE INTEGRAL

INOX
GAZ / NPT / SW / BW
PN64

97/23/CE Catégorie III
ATEX

CORPS / BODY	INOX 316
EMBOUITS / END CONNECTIONS	INOX 316
SPHERE / BALL	INOX 316
SIEGES / SEATS	PTFE
TIGE / STEM	INOX 316
POIGNEE / HANDLE	ACIER ZINGUE
P. ETOUPE / PACKING GLAND	VITON

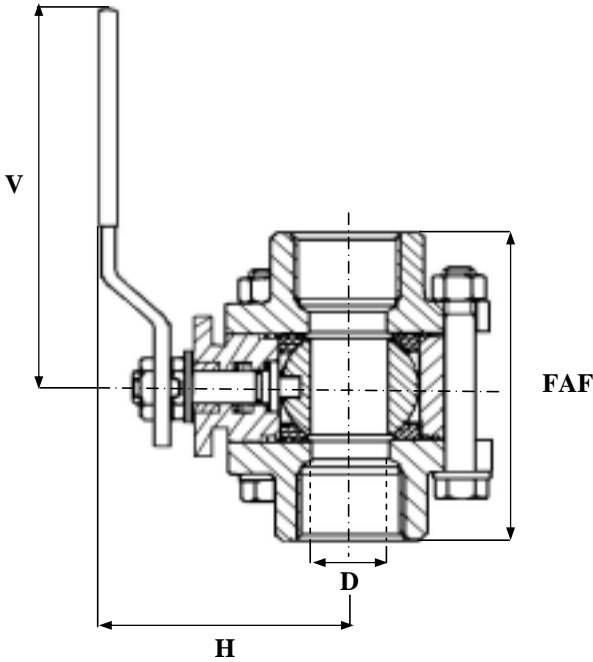

TEMPERATURE MAXI SERVICE 220°C

PRESSION MAXI DE SERVICE 64B

LE RAPPORT PRESSION/TEMPERATURE EST A DEFINIR PAR NOS SOINS

REF : 100 239
SÉCURITÉ FEU SELON BS 6755/2

SOUS RESERVE DE MODIFICATIONS

D	8	10	15	20	25	32	40	50	65	80	100	125	150	200	250	300	350	400	500	600
N	1/4	3/8	1/2	3/4	1	1 1/4	1 1/2	2	2 1/2	3	4	5	6	8	10	12	14	16	20	24
FAF	65	65	65	73	90	98	104	125	190	203	229									
H	64	64	64	66	85	90	118	126	139	144	195									
D	8	10	14	19	24	29	38	48	64	76	95									
V	145	145	145	145	180	180	275	275	380	380	440									
MASSE	0.7	0.7	0.7	1.2	1.5	2	3.3	5	11.5	15	24									

A