

DINEX® ROBINET TOURNANT SPHERIQUE

MONOBLOC

PASSAGE INTEGRAL

ACIER

GAZ / NPT

PN100

97/23/CE Catégorie III
ATEX

CORPS / BODY	ACIER A 105
EMBOUT / END CONNECTION	ACIER A 105
SPHERE / BALL	INOX 304
SIEGES / SEATS	PTFE
TIGE / STEM	INOX F6
POIGNEE / HANDLE	ACIER
P. ETOUPE / PACKING GLAND	PTFE

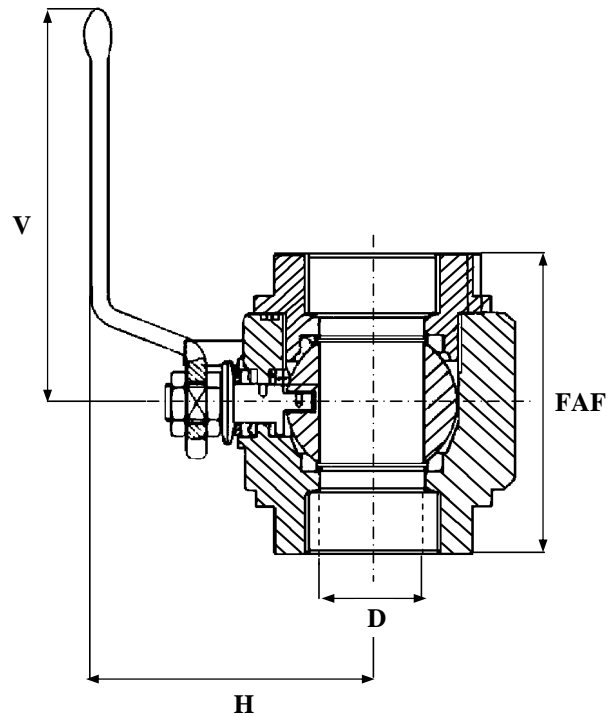

TEMPERATURE MAXI SERVICE 180°C

PRESSION MAXI DE SERVICE 100B

LE RAPPORT PRESSION/TEMPERATURE
EST A DEFINIR PAR NOS SOINS

REF : 100 316

SÉCURITÉ FEU SELON BS 6755/2

SOUS RESERVE DE MODIFICATIONS

D	8	10	15	20	25	32	40	50	65	80	100	125	150	200	250	300	350	400	500	600	
N	1/4	3/8	1/2	3/4	1	1 1/4	1 1/2	2	2 1/2	3	4	5	6	8	10	12	14	16	20	24	
FAF	50	60	75	80	90	110	120	140													
H	46	46	63	65	76	80	98	108													
D	10	10	15	19	25	30	38	51													
V	120	120	145	145	185	185	28	280													
MASSE	0.60	0.65	1.20	1.40	2.20	3.20	5.20	8													

11907

19 rue Albert Thomas 44600 SAINT NAZAIRE - FRANCE

TEL : 02.51.10.18.18 FAX : 02.51.10.18.19

www.societe-gmi.com

REV .05

PAGE A160