

PRO-DINEX® ROBINET TOURNANT SPHERIQUE

SPLIT BODY
NORME DIN
PASSAGE INTEGRAL

FONTE
BRIDES
ISO PN16

97/23/CE Catégorie I

CORPS / BODY	FONTE FT 25
EMBOUT / END CONNECTION	FONTE GG 25
SPHERE / BALL	LAITON CHROME DUR
SIEGES / SEATS	PTFE CHARGE
TIGE / STEM	LAITON
POIGNEE / HANDLE	ACIER
P. ETOUPE / PACKING GLAND	PTFE

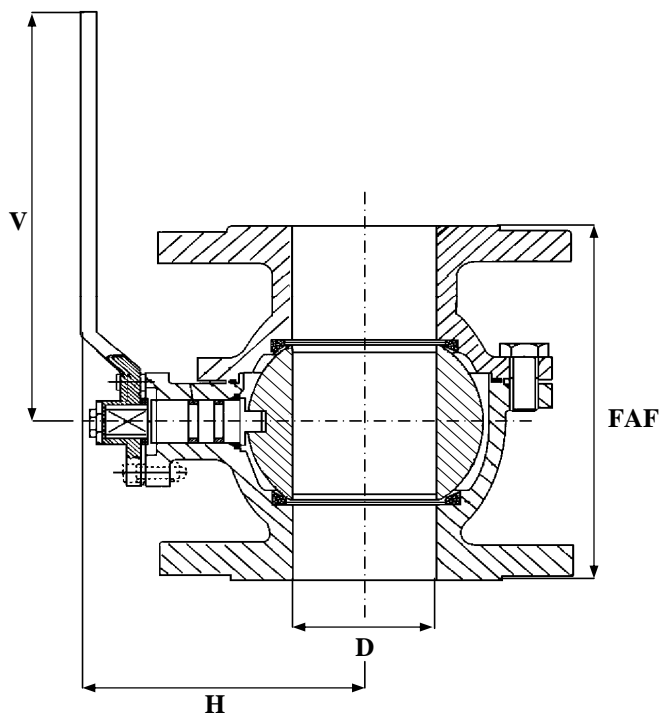

TEMPERATURE MAXI SERVICE 120°C

PRESSION MAXI DE SERVICE 12B

LE RAPPORT PRESSION/TEMPERATURE EST A DEFINIR PAR NOS SOINS

REF : 100 331

OPTIONS :

- * SPHERE INOX
- * ECARTEMENT NFE

NORMES :

* DIN 3202 F4/F5 SERIE COURTE

D	8	10	15	20	25	32	40	50	65	80	100	125	150	200	250	300	350	400	500	600	
N	1/4	3/8	1/2	3/4	1	1 1/4	1 1/2	2	2 1/2	3	4	5	6	8	10	12	14	16	20	24	
FAF							140	150	170	180	190	200	210	400							
H							90	107	115	140	150	200	205	334							
D							DN 200 : PN10		40	50	61	75	95	120	145	200					
V							165	240	260	260	260	420	420	700							
MASSE							7	10	13	15	20	32	40	90							

SOUS RESERVE DE MODIFICATIONS

19 rue Albert Thomas 44600 SAINT NAZAIRE - FRANCE

TEL : 02.51.10.18.18 FAX : 02.51.10.18.19

www.societe-gmi.com

REV .05

PAGE A310