

## PRO-DINEX® ROBINET TOURNANT SPHERIQUE

SANDWICH

PASSAGE INTEGRAL

**ACIER**

BRIDES

ISO PN50

97/23/CE Catégorie III  
ATEX

CORPS / BODY	ACIER A 216 WCB (A 105)
EMBOU / END CONNECTION	ACIER A 216 WCB (A 105)
SPHERE / BALL	INOX 316
SIEGES / SEATS	PTFE CHARGE
TIGE / STEM	INOX 316
POIGNEE / HANDLE	ACIER
P. ETOUPE / PACKING GLAND	PTFE

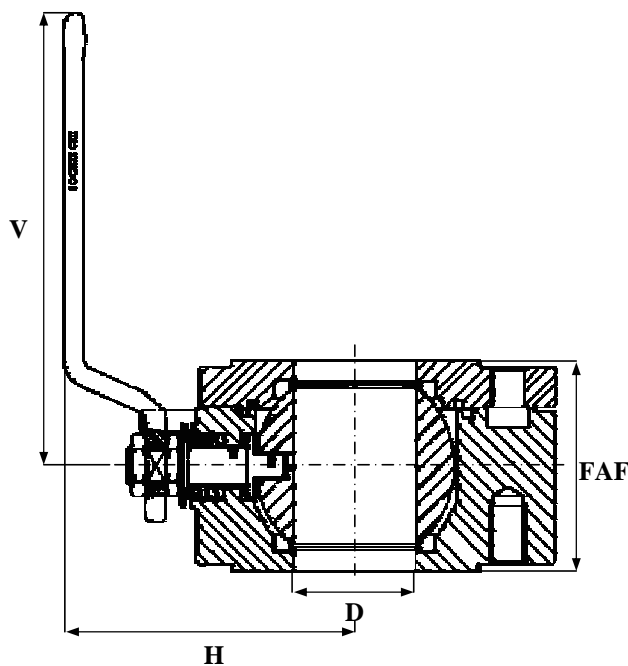

TEMPERATURE MAXI SERVICE 180°C

PRESSION MAXI DE SERVICE 50B

LE RAPPORT PRESSION/TEMPERATURE  
EST A DEFINIR PAR NOS SOINS

**REF : 100 392**

OPTIONS :

\* PASSAGE REDUIT

NORMES :

\* SECURITE FEU BS 6755/2

D	8	10	15	20	25	32	40	50	65	80	100	125	150	200	250	300	350	400	500	600	
N	1/4	3/8	1/2	3/4	1	1 1/4	1 1/2	2	2 1/2	3	4	5	6	8	10	12	14	16	20	24	
FAF			35	39	43	51	64	85	103	120	155	182	234	310							
H			66	68	85	91	110	120	144	152	174	188	256	294							
D			15	19	25	30	38	51	64	76	101	118	152	203							
V			145	145	185	185	280	280	370	370	470	650	750	900							
MASSE			1.60	2	2.80	5	7.2	11	18	23	33	48	82	120							

SOUS RESERVE DE MODIFICATIONS

19 rue Albert Thomas 44600 SAINT NAZAIRE - FRANCE

TEL : 02.51.10.18.18 FAX : 02.51.10.18.19

www.societe-gmi.com

REV .05

PAGE A360