

### HYDRO-DINEX® ROBINET TOURNANT SPHERIQUE

**HAUTE PRESSION**  
**3 VOIES EN L**  
**PASSAGE REDUIT**

**ACIER**  
**GAZ**  
**PN500**

97/23/CE art 3,§3

CORPS / BODY	ACIER BICHROMATE
EMBOUTS / END CONNECTIONS	ACIER BICHROMATE
SPHERE / BALL	ACIER CHROME
SIEGES / SEATS	DELIRIN /PTFE
TIGE / STEM	INOX 304
POIGNEE / HANDLE	ALUMINIUM
P. ETOUPE / PACKING GLAND	NBR

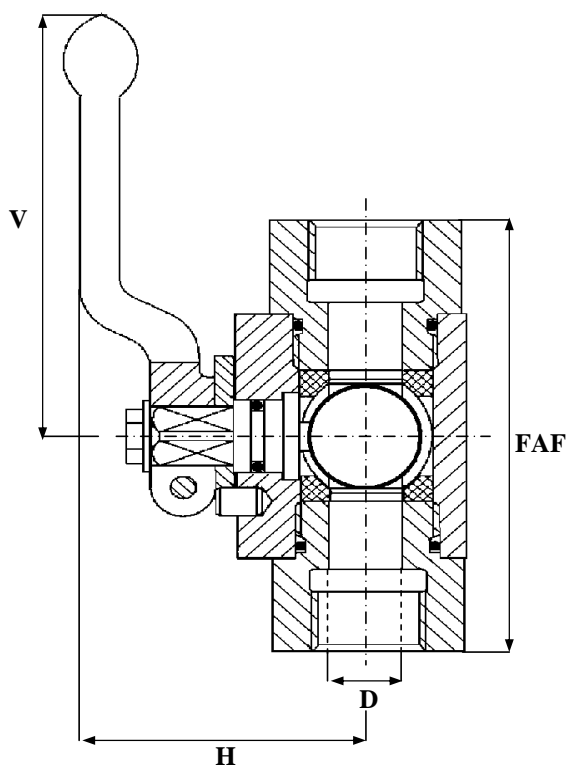

TEMPERATURE MAXI SERVICE 100°C

PRESSION MAXI DE SERVICE 500B <= 1/2"  
 PRESSION MAXI DE SERVICE 315B >= 3/4"

LE RAPPORT PRESSION/TEMPERATURE  
 EST A DEFINIR PAR NOS SOINS

**REF : 100 610**

**OPTIONS :**

\* SELON LES JOINTS : CONFIGURATION POSSIBLE  
 POUR TENUE A LA TEMPERATURE (maxi 220°) OU  
 FLUIDES PARTICULIERS.

SOUS RESERVE DE MODIFICATIONS

D	8	10	15	20	25	32	40	50	65	80	100	125	150	200	250	300	350	400	500	600	
N	1/4	3/8	1/2	3/4	1	1 1/4	1 1/2	2	2 1/2	3	4	5	6	8	10	12	14	16	20	24	
FAF	71	73	83	95	112	120															
H	71	52	63	75	83	83															
D	6	10	13	20	25	25															
V	110	110	110	180	180	180															
MASSE	0.5	0.7	0.8	1.5	2.35	2.5															