

### PRO-DINEX® ROBINET TOURNANT SPHERIQUE

3 VOIES

PASSAGE INTEGRAL

**ACIER**

BRIDES

ISO PN16

97/23/CE Catégorie II

CORPS / BODY	ACIER A 216 WCB
EMBOUS / END CONNECTIONS	ACIER A 216 WCB
SPHERE / BALL	INOX 316
SIEGES / SEATS	PTFE CHARGE
TIGE / STEM	INOX 316
POIGNEE / HANDLE	FONTE GS
P. ETOUPE / PACKING GLAND	PTFE

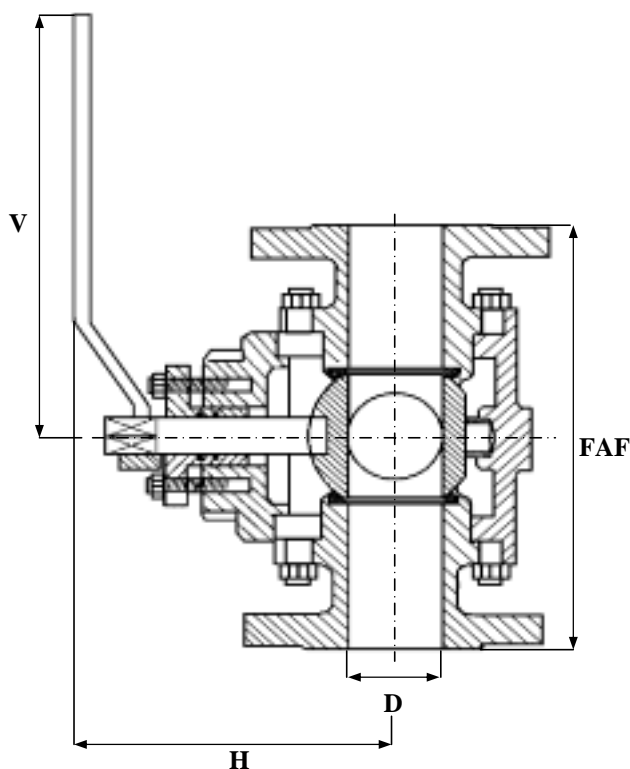

TEMPERATURE MAXI SERVICE 180°C

PRESSION MAXI DE SERVICE 16B

LE RAPPORT PRESSION/TEMPERATURE EST A DEFINIR PAR NOS SOINS

REF : 100 340 PERCAGE L

REF : 100 341 PERCAGE T

SOUS RESERVE DE MODIFICATIONS

D	8	10	15	20	25	32	40	50	65	80	100	125	150	200	250	300	350	400	500	600	
N	1/4	3/8	1/2	3/4	1	1 1/4	1 1/2	2	2 1/2	3	4	5	6	8	10	12	14	16	20	24	
FAF								250	285	295	340	410	450	600							
H								107	142	152	178	220	272	300							
D								50	63	76	100	125	150	200							
V								260	320	320	400	550	550	550							
MASSE								30	45	60	95	110	140	160							