

DINO-LURIA® VANNE A PASSAGE DIRECT

**CORPS MEPLAT
DIN F4
TIGE INTERIEURE**

**FORTE
BRIDES
ISO PN10***

CORPS / BODY	FORTE GG 25
CHAPEAU / BONNET	FORTE GG 25
OPERCULE WEDGE	FORTE GG 25 + LAITON (ou INOX F6)
SIEGES / SEATS	LAITON (ou INOX F6)
TIGE / STEM	INOX F6
JOINT DE CORPS / GASKET	GRAPHITE
P. ETOUPE / PACKING GLAND	FIBRE GRAPHITE

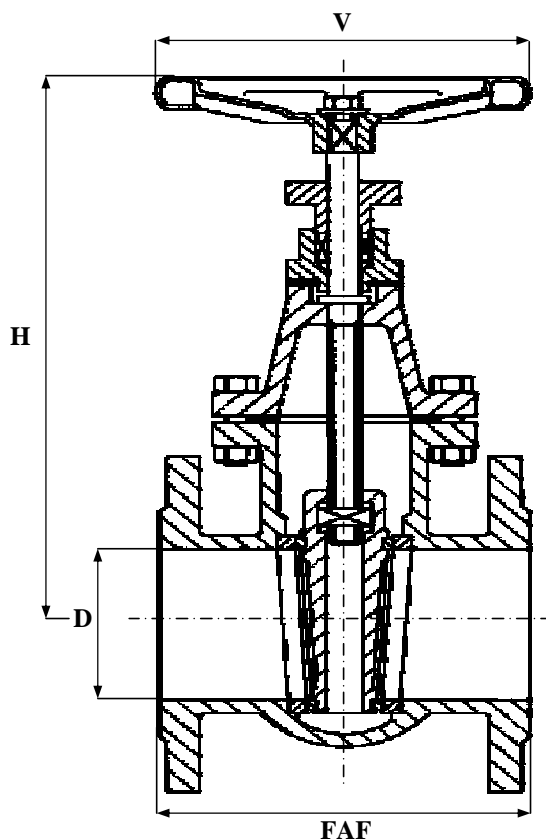

REF : 153 100

LIMITES D' UTILISATION

TEMPERATURE MAXI : 120 °C

DN40 DN50 DN65 DN80 DN100 DN125 DN150	10 Bars
DN200 DN250 DN300	6 Bars
DN350 DN400 DN500	4 Bars
DN600	2.5 Bars

OPTIONS :

* AVEC SIEGES INOX - REF : 153 105

NORMES :

* DIN 3202 F4 SERIE COURTE

D	8	10	15	20	25	32	40	50	65	80	100	125	150	200	250	300	350	400	500	600
N	1/4	3/8	1/2	3/4	1	1 1/4	1 1/2	2	2 1/2	3	4	5	6	8	10	12	14	16	20	24
FAF							140	150	170	180	190	200	210	230	250	270	290	310	350	390
H							239	253	285	307	363	443	450	515	605	692	825	866	1060	1240
D							40	50	65	80	100	125	150	200	250	300	350	400	500	600
V							120	140	160	160	180	200	200	250	280	320	320	400	500	500
MASSE							11	14	19	22	28	53	61	66	91	169	266	307	473	563

SOUS RESERVE DE MODIFICATIONS