

DINO-LURIA® VANNE A PASSAGE DIRECT

CORPS MEPLAT

TIGE MONTANTE

FORTE

BRIDES

ISO PN10 (1)

CORPS / BODY	FORTE GG 25
CHAPEAU / BONNET	FORTE GG 25
OPERCULE WEDGE	FORTE GG 25 + LAITON (ou INOX F6)
SIEGES / SEATS	LAITON (ou INOX F6)
TIGE / STEM	INOX F6
JOINT DE CORPS / GASKET	GRAPHITE
P. ETOUPE / PACKING GLAND	FIBRE GRAPHITEE

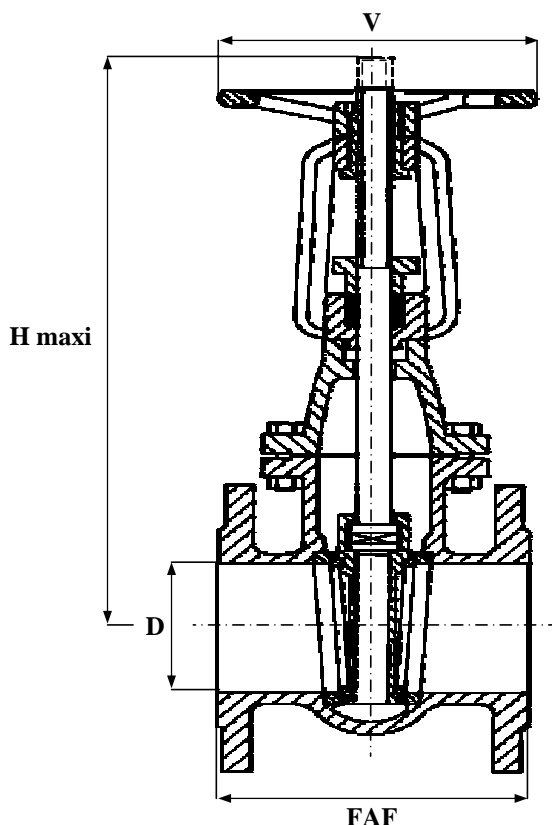

REF : 153 103

OPTIONS :

* AVEC SIEGES INOX - REF : 153 104

NORMES :

* DIN 3202 F4 SERIE COURTE

(1) **LIMITES D'UTILISATION**

TEMPERATURE MAXI : 120 °C

DN40 DN50 DN65 DN80 DN100 DN125 DN150	10 BARS
DN200 DN250 DN300	6 BARS
DN350 DN400 DN500	4 BARS
DN600	2.5 BARS

SOUS RESERVE DE MODIFICATIONS

D	8	10	15	20	25	32	40	50	65	80	100	125	150	200	250	300	350	400	500	600
N	1/4	3/8	1/2	3/4	1	1 1/4	1 1/2	2	2 1/2	3	4	5	6	8	10	12	14	16	20	24
FAF							140	150	170	180	190	200	210	230	250	270	290	310	350	390
H maxi							334	355	435	482	546	725	760	980	1154	1375	1570	1730	2140	2540
D							40	50	65	80	100	125	150	200	250	300	350	400	500	600
V							140	140	180	180	200	200	200	250	315	315	320	400	500	500
MASSE							12	15	20	28	34	60	67	78	105	185	280	325	505	605