

DINO-LURIA® VANNE A PASSAGE DIRECT

COIN FLEXIBLE

TIGE EXTERIEURE

ACIER

BRIDES

ISO PN16

CORPS / BODY	ACIER GSC 25
CHAPEAU / BONNET	ACIER GSC 25
OPERCULE / WEDGE	ACIER GSC 25 + INOX F6
SIEGES / SEATS	INOX F6
TIGE / STEM	INOX F6
JOINT DE CORPS / GASKET	GRAPHITE
P. ETOUPE / PACKING GLAND	FIBRE GRAPHITEE

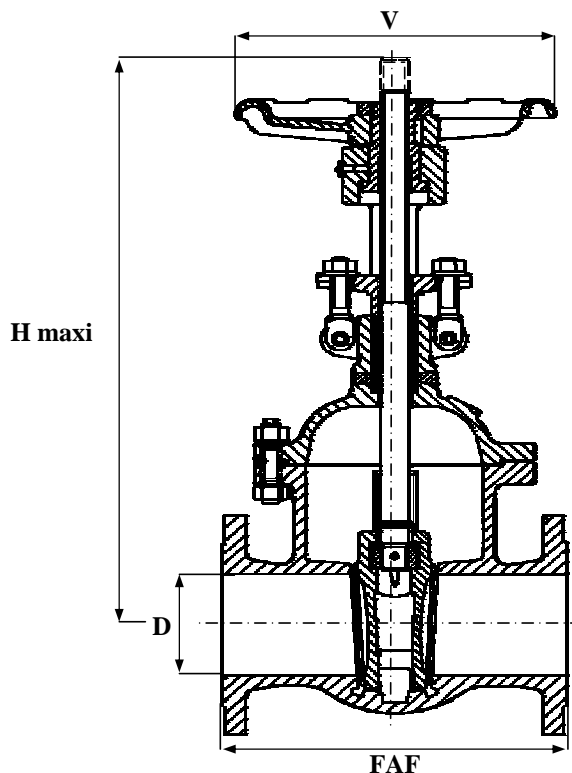

TEMPERATURE MAXI SERVICE 300°C

PRESSION MAXI DE SERVICE 16B

LE RAPPORT PRESSION/TEMPERATURE EST A DEFINIR PAR NOS SOINS

REF : 153 110

NORMES :

* DIN 3205 F5 SERIE LONGUE = DN + 200

D	8	10	15	20	25	32	40	50	65	80	100	125	150	200	250	300	350	400	500	600
N	1/4	3/8	1/2	3/4	1	1 1/4	1 1/2	2	2 1/2	3	4	5	6	8	10	12	14	16	20	24
FAF							240	250	270	280	300	325	350	400	450	500	550	600	700	800
H maxi							340	350	430	480	620	725	800	1025	1310	1440	1650	1885	2310	2635
D							40	50	65	80	100	125	150	200	250	300	350	400	500	600
V							220	220	220	275	275	360	360	360	450	450	450	560	630	700
MASSE							18	25	38	45	55	78	96	158	230	340	395	565	880	1250

SOUS RESERVE DE MODIFICATIONS