

DINO-LURIA® VANNE A PASSAGE DIRECT

COIN FLEXIBLE

TIGE EXTERIEURE

ACIER

BRIDES

ISO PN25

CORPS / BODY	ACIER GSC 25
CHAPEAU / BONNET	ACIER GSC 25
OPERCULE / WEDGE	ACIER GSC 25 + INOX F6
SIEGES / SEATS	INOX F6
TIGE / STEM	INOX F6
JOINT DE CORPS / GASKET	GRAPHITE
P. ETOUPE / PACKING GLAND	FIBRE GRAPHITEE

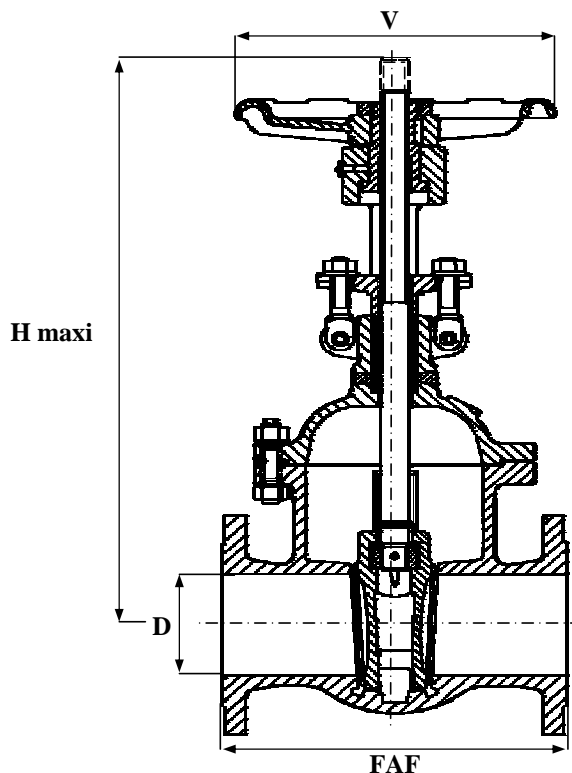

TEMPERATURE MAXI SERVICE 450°C

PRESSION MAXI DE SERVICE 25B

LE RAPPORT PRESSION/TEMPERATURE EST A DEFINIR PAR NOS SOINS

REF : 153 111

NORMES :

* DIN 3205 F5 SERIE LONGUE = DN + 200

D	8	10	15	20	25	32	40	50	65	80	100	125	150	200	250	300	350	400	500	600
N	1/4	3/8	1/2	3/4	1	1 1/4	1 1/2	2	2 1/2	3	4	5	6	8	10	12	14	16	20	24
FAF							240	250	270	280	300	325	350	400	450	500	550	600	700	800
H maxi							340	350	430	480	620	730	880	1040	1235	1440	1650	1885	2310	2635
D							40	50	65	80	100	125	150	200	250	300	350	400	500	600
V							230	230	250	250	320	320	320	450	450	500	500	640	800	800
MASSE							18	25	38	47	57	80	132	175	290	386	545	730	1400	1630

SOUS RESERVE DE MODIFICATIONS

19 rue Albert Thomas 44600 SAINT NAZAIRE - FRANCE

TEL : 02.51.10.18.18 FAX : 02.51.10.18.19

www.societe-gmi.com

REV .05

PAGE B150