

DINO-LURIA® VANNE A PASSAGE DIRECT

COIN FLEXIBLE

TIGE EXTERIEURE

ACIER

BRIDES

ISO PN40

CORPS / BODY	ACIER GSC 25
CHAPEAU / BONNET	ACIER GSC 25
OPERCULE / WEDGE	ACIER GSC 25 + INOX F6
SIEGES / SEATS	INOX F6
TIGE / STEM	INOX F6
JOINT DE CORPS / GASKET	GRAPHITE
P. ETOUPE / PACKING GLAND	FIBRE GRAPHITEE

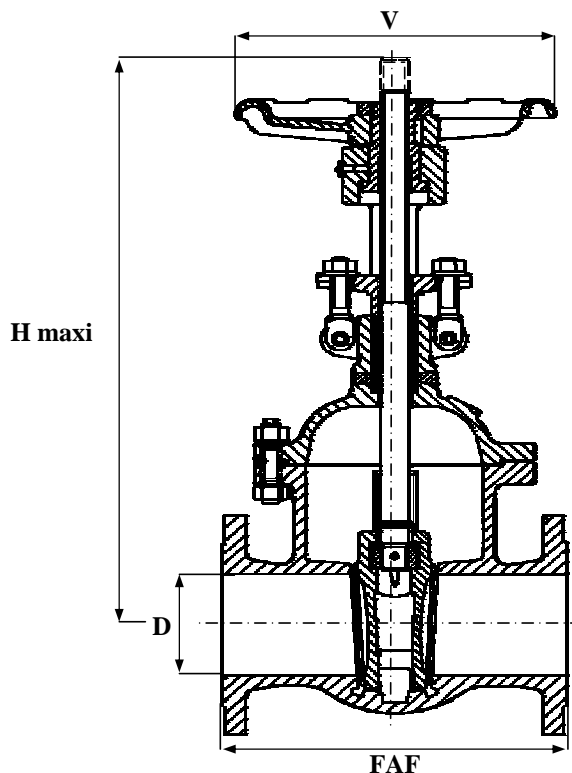

TEMPERATURE MAXI SERVICE 450°C

PRESSION MAXI DE SERVICE 40B

LE RAPPORT PRESSION/TEMPERATURE EST A DEFINIR PAR NOS SOINS

REF : 153 112

NORMES :

* DIN 3205 F7

D	8	10	15	20	25	32	40	50	65	80	100	125	150	200	250	300	350	400	500	600
N	1/4	3/8	1/2	3/4	1	1 1/4	1 1/2	2	2 1/2	3	4	5	6	8	10	12	14	16	20	24
FAF							240	250	290	310	350	400	450	550	650	750	850	950	1150	1350
H maxi							370	400	520	570	630	730	880	1040	1235	1390	1610	1830	2250	2510
D							40	50	65	80	100	125	150	200	250	300	350	400	500	600
V							230	230	250	250	305	320	355	457	457	559	630	710	900	1000
MASSE							18	25	39	47	59	80	138	198	312	392	710	1223	1750	2400

SOUS RESERVE DE MODIFICATIONS