

DINO-LURIA® VANNE A PASSAGE DIRECT

COIN FLEXIBLE

TIGE EXTERIEURE

INOX

BRIDES

ISO PN16

CORPS / BODY	INOX A 351 CF8M (316)
CHAPEAU / BONNET	INOX A 351 CF8M (316)
OPERCULE / WEDGE	INOX A 351 CF8M (316)
SIEGES / SEATS	INOX 316
TIGE / STEM	INOX 316L
JOINT DE CORPS / GASKET	GRAPHITE
P. ETOUPE / PACKING GLAND	FIBRE GRAPHITEE

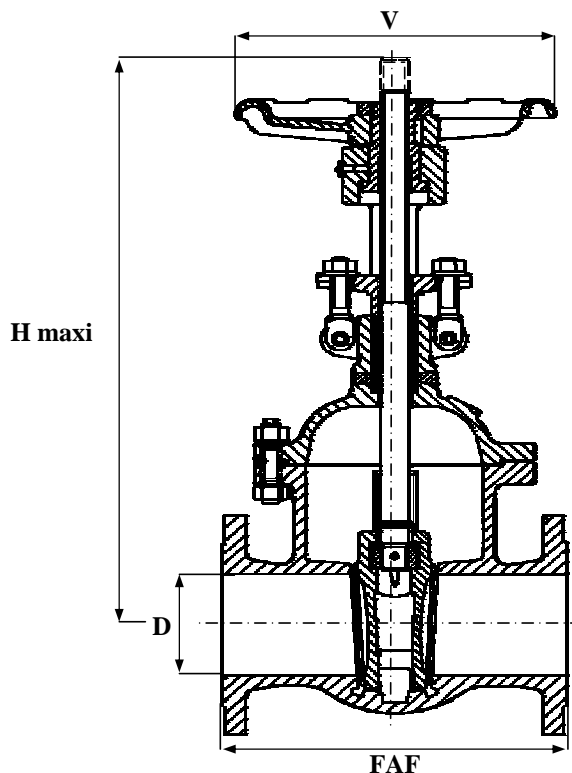

TEMPERATURE MAXI SERVICE 300°C

PRESSION MAXI DE SERVICE 16B

LE RAPPORT PRESSION/TEMPERATURE EST A DEFINIR PAR NOS SOINS

REF : 153 210

PERCAGE POSSIBLE EN PN10

NORMES :

* DIN 3205 F4

D	8	10	15	20	25	32	40	50	65	80	100	125	150	200	250	300	350	400	500	600	
N	1/4	3/8	1/2	3/4	1	1 1/4	1 1/2	2	2 1/2	3	4	5	6	8	10	12	14	16	20	24	
FAF							140	150	170	180	190	200	210	230	250	270	290				
H maxi							286	308	370	394	481	539	623	692	753	1120	1200				
D							40	50	65	80	100	125	150	200	250	300	350				
V							160	160	200	200	250	320	320	360	450	500	500				
MASSE							12	15	20	24	30	55	65	70	100	175	250				

SOUS RESERVE DE MODIFICATIONS