

ROBINET A POINTEAU

SERIE "FORGEE"

ACIER

GAZ

PN200

97/23/CE art 3,§3

CORPS / BODY	ACIER A 105
TETE / BONNET	ACIER A 105
POINTEAU / NEEDLE	INOX 304
SIEGE / SEAT	INOX 304
TIGE / STEM	INOX 304
JOINT DE CORPS / GASKET	GRAPHITE
P. ETOUPE / PACKING GLAND	GRAPHITE

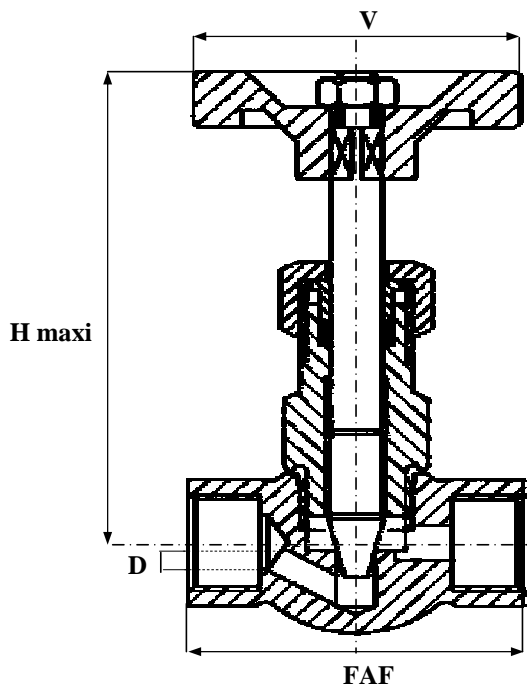

TEMPERATURE MAXI SERVICE 300°C

PRESSION MAXI DE SERVICE 200B

LE RAPPORT PRESSION/TEMPERATURE EST A DEFINIR PAR NOS SOINS

REF : 104 004

SOUS RESERVE DE MODIFICATIONS

D	8	10	15	20	25	32	40	50	65	80	100	125	150	200	250	300	350	400	500	600
N	1/4	3/8	1/2	3/4	1	1 1/4	1 1/2	2	2 1/2	3	4	5	6	8	10	12	14	16	20	24
FAF	60	60	70	75	90															
H	85	85	98	112	134															
D	4	5	6	8	8.5															
V	78	78	78	78	98															
MASSE	0.65	0.65	0.85	1.05	1.95															