

### DINO-STILI® ROBINET A SOUPE

ETANCHEITE

PRESSE ETOUPE

**FONTE**

BRIDES

ISO PN16

97/23/CE art 3,§3

CORPS / BODY	FONTE GG 25
CHAPEAU / BONNET	FONTE GG 25
SOUPE / DISC	FONTE GG 25 + INOX F6
SIEGE / SEAT	INOX F6
TIGE / STEM	INOX F6
JOINT DE CORPS / GASKET	GRAPHITE
P. ETOUPE / PACKING GLAND	FIBRE GRAPHITEE

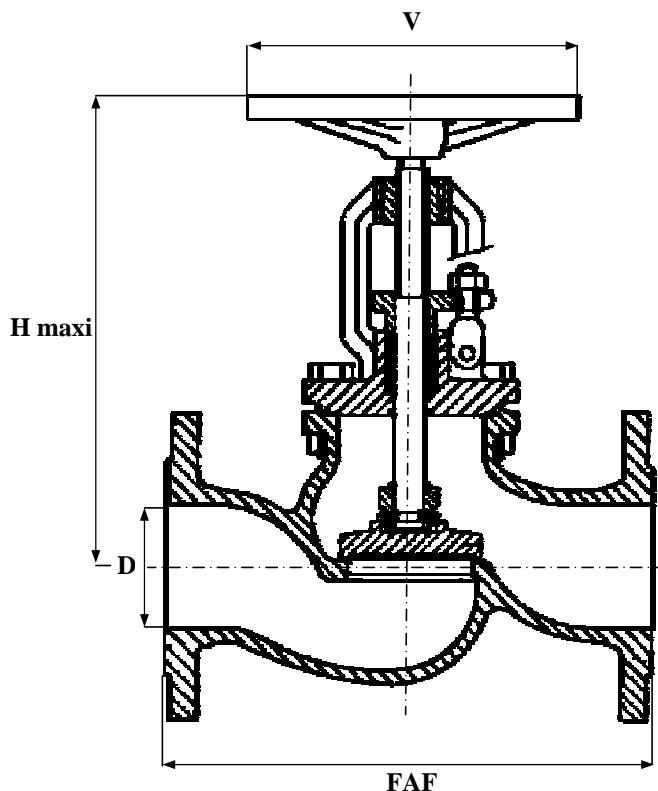

TEMPERATURE MAXI SERVICE 120°C

PRESSION MAXI DE SERVICE 16B

LE RAPPORT PRESSION/TEMPERATURE EST A DEFINIR PAR NOS SOINS

**REF : 101 100**

**NORMES :**

\* DIN 3202 F1

D	8	10	15	20	25	32	40	50	65	80	100	125	150	200	250	300	350	400	500	600
N	1/4	3/8	1/2	3/4	1	1 1/4	1 1/2	2	2 1/2	3	4	5	6	8	10	12	14	16	20	24
FAF			130	150	160	180	200	230	290	310	350	400	480	600	730	850	980	1100		
H			176	180	232	238	262	272	323	353	381	453	502	620	691	760	860	880		
D			15	20	25	32	40	50	65	80	100	125	150	200	250	300	350	400		
V			100	100	120	120	140	140	160	200	280	320	360	400	400	520	520	520		
MASSE			4.2	4.7	5.7	7.6	10	14	25	30	41	67	96	143.5	207	277	530	600		

SOUS RESERVE DE MODIFICATIONS

19 rue Albert Thomas 44600 SAINT NAZAIRE - FRANCE

TEL : 02.51.10.18.18 FAX : 02.51.10.18.19

www.societe-gmi.com

REV .05

PAGE C130