

DINO-STILI® ROBINET A SOUPE

SIEGE INCLINE

PRESSE ETOUPE

INOX

BRIDES

ISO PN16

97/23/CE Catégorie III

CORPS / BODY	INOX A 351 CF8M
CHAPEAU / BONNET	INOX A 351 CF8M
SOUPE / DISC	INOX 316
SIEGE / SEAT	INOX 316
TIGE / STEM	INOX 316
JOINT DE CORPS / GASKET	GRAPHITE
P. ETOUPE / PACKING GLAND	FIBRE GRAPHITEE

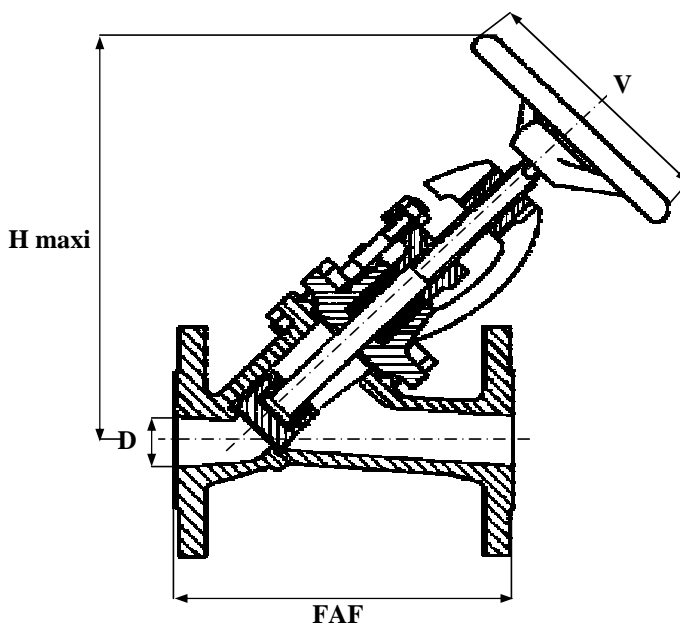

TEMPERATURE MAXI SERVICE 300°C

PRESSION MAXI DE SERVICE 16B

LE RAPPORT PRESSION/TEMPERATURE EST A DEFINIR PAR NOS SOINS

REF : 101 103

NORMES :

* DIN 3202 F1

D	8	10	15	20	25	32	40	50	65	80	100	125	150	200	250	300	350	400	500	600	
N	1/4	3/8	1/2	3/4	1	1 1/4	1 1/2	2	2 1/2	3	4	5	6	8	10	12	14	16	20	24	
FAF			130	150	160	180	200	230	290	310	350	400	480	600	730						
H			180	220	225	140	270	300	360	360	430	540	620	664	750						
D			15	20	25	32	40	50	65	80	100	125	150	200	250						
V			100	125	125	125	160	160	200	200	250	320	380	450	500						
MASSE			2.9	3.3	3.7	7.6	8.7	10.7	21	25.15	34	55	77	125	160						

SOUS RESERVE DE MODIFICATIONS

19 rue Albert Thomas 44600 SAINT NAZAIRE - FRANCE

TEL : 02.51.10.18.18 FAX : 02.51.10.18.19

www.societe-gmi.com

REV .05

PAGE C220