

DINO-STILI® ROBINET A SOUPE

ETANCHEITE

PRESSE ETOUPE

INOX

BRIDES

ISO PN16

97/23/CE art 3,§3

CORPS / BODY	INOX 351 CF8M
CHAPEAU / BONNET	INOX 351 CF8M
SOUPE / DISC	INOX 316
SIEGE / SEAT	INOX 316
TIGE / STEM	INOX 316
JOINT DE CORPS / GASKET	GRAPHITE
P. ETOUPE / PACKING GLAND	FIBRE GRAPHITEE

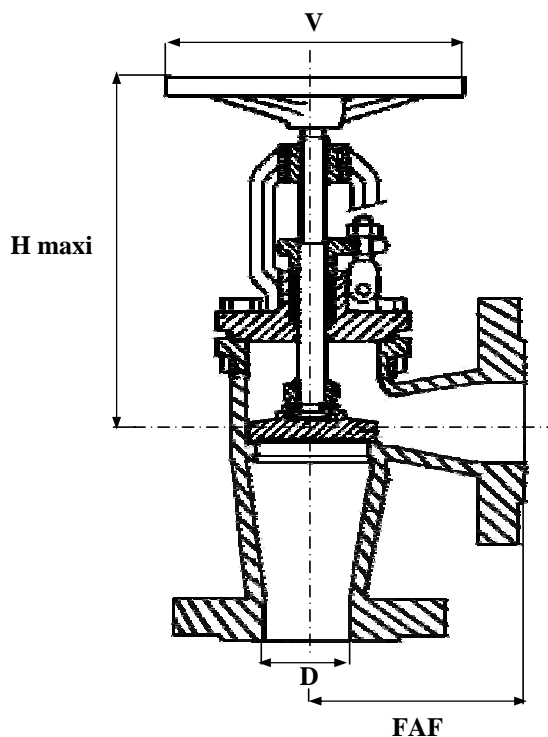

TEMPERATURE MAXI SERVICE 300°C

PRESSION MAXI DE SERVICE 16B

REF : 101 220

LE RAPPORT PRESSION/TEMPERATURE EST A DEFINIR PAR NOS SOINS

NORMES :

* DIN 3202 F1

SOUS RESERVE DE MODIFICATIONS

D	8	10	15	20	25	32	40	50	65	80	100	125	150	200	250	300	350	400	500	600
N	1/4	3/8	1/2	3/4	1	1 1/4	1 1/2	2	2 1/2	3	4	5	6	8	10	12	14	16	20	24
FAF			65	75	80	90	100	115	145	155	175	200	240	300	365					
H			203	215	227	238	251	267	318	346	397	451	491	546	630					
D			15	20	25	32	40	50	65	80	100	125	150	200	250					
V			125	125	125	150	160	160	200	200	250	320	380	450	500					
MASSE			4.5	5.5	7	9	12	16	22.1	27.2	44	70	92.5	178	275					