

## DINO-STILI® ROBINET A SOUPE

SERIE PETROLE

**INOX**  
BRIDES RF  
ISO PN20 - PN50 - PN100  
97/23/CE Catégorie III

CORPS / BODY	INOX A 351 CF8M (316)
CHAPEAU / BONNET	INOX A 351 CF8M (316)
SOUPE / DISQUE	INOX A 351 CF8M (316)
SIEGE / SEAT	INOX F6
TIGE / STEM	INOX F6
JOINT DE CORPS / GASKET	GRAPHITE OU SPIRALE
P. ETOUPE / PACKING GLAND	GRAPHITE

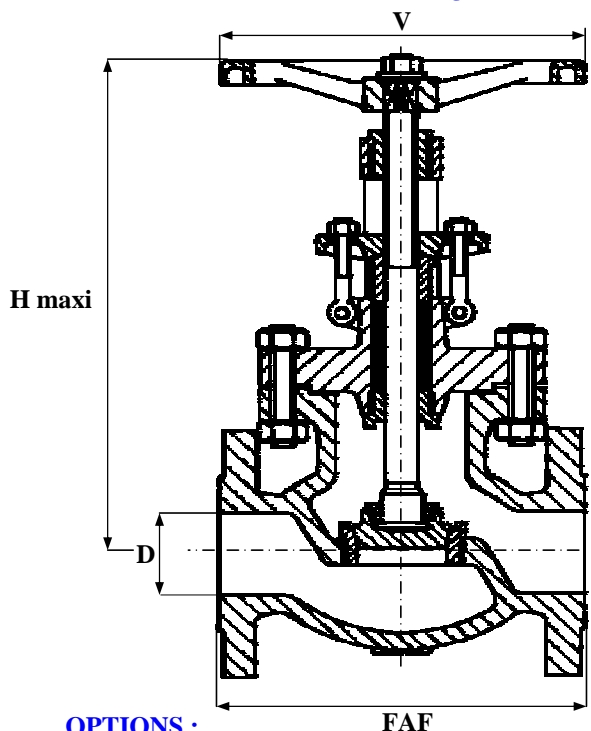

**NORMES :**

- \*API 600 - API 598
- \*ANSI B 16.10 - ANSI B 16.34

**OPTIONS :**

- \*AUTRES MATIERES
- \*DIFFERENTS TRIMS
- \*RACCORDEMENT RTJ - BW

	D	50	65	80	100	150	200	250	300	350	400	450	500	600
		N	2	2 1/2	3	4	6	8	10	12	14	16	18	20
106 025 ISO PN20	FAF	203		241	292	406	495	622	699	787	914	978	489	591
	H maxi	309		399	457	574	689	834	923	1025	1495	1595	1625	1798
	V	216		254	310	457	560	560	610	610	640	100	1200	1200
	MASSE	22		42	64	77	105	288	507	617	810	1205	1720	2506
106 055 ISO PN50	FAF	267		317	356	445	559	622	711	787	838	978		
	H maxi	376		524	617	741	879	834	996	1068	1535	1717		
	V	200		250	350	450	560	560	640	640	100	1200		
	MASSE	31		57	86	168	280	385	724	978	1336	1896		
106 105 ISO PN100	FAF	292		356	432	559	660	787	838	889	991			
	H maxi	548		522	677	841	996	1040	1275	1550	1740			
	V	250		350	450	500	560	640	640	1200	1500			
	MASSE	39		73	120	327	482	700	900	1589	2277			

SOUS RESERVE DE MODIFICATIONS