

### ECO-DIRIS® CLAPET A BATTANT

METAL / METAL

**INOX**  
GAZ / NPT  
PN16

97/23/CE Catégorie I

CORPS / BODY	INOX 316
CHAPEAU / BONNET	INOX 316
BATTANT / DISC	INOX 316
SIEGE / SEAT	INOX 316
JOINT / GASKET	PLAT PTFE

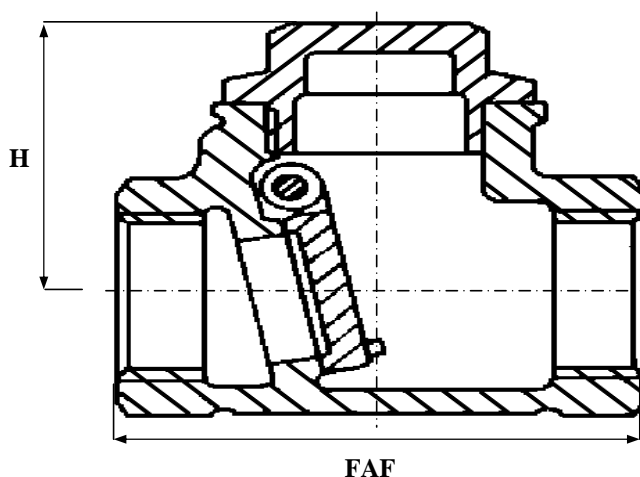

TEMPERATURE MAXI SERVICE 150°C

PRESSION MAXI DE SERVICE 16B

**REF : 220 006**

LE RAPPORT PRESSION/TEMPERATURE  
EST A DEFINIR PAR NOS SOINS

SOUS RESERVE DE MODIFICATIONS

D	8	10	15	20	25	32	40	50	65	80	100	125	150	200	250	300	350	400	500	600
N	1/4	3/8	1/2	3/4	1	1 1/4	1 1/2	2	2 1/2	3	4	5	6	8	10	12	14	16	20	24
FAF	65	65	65	80	90	105	120	140												
H	42	42	42	51	60	66	75	80												
MASSE	0.30	0.30	.030	0.42	0.66	1.02	1.44	2.14												

19 rue Albert Thomas 44600 SAINT NAZAIRE - FRANCE

TEL : 02.51.10.18.18 FAX : 02.51.10.18.19

www.societe-gmi.com

REV .05

PAGE E060