

## PRO-DIRIS® CLAPET A BILLE

FORGE

CHAPEAU BOULONNE

INOX

NPT / SW / BW

800LBS

97/23/CE Catégorie III

CORPS / BODY	INOX 316L
CHAPEAU / BONNET	INOX 316L
BILLE / BALL	INOX 316L
SIEGE / SEAT	INOX 316L
JOINT / GASKET	SPIRALE INOX 316L + GRAPHITE

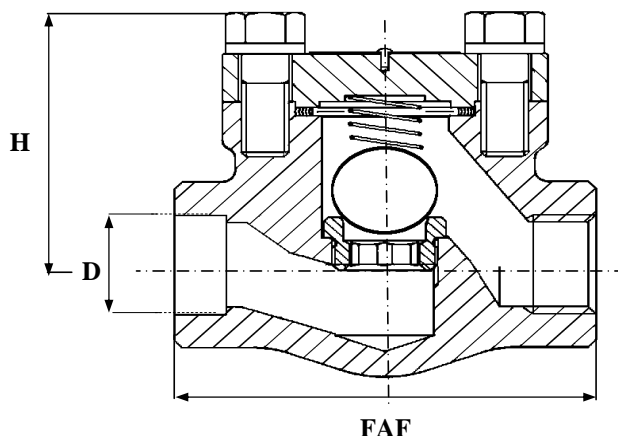

235 1 (1500 lbs)  
 8 (800 lbs) 50 (VOIR TABLEAU)  
 2 (2500 lbs)

CHAPEAU	PASSAGE		CONTACTS
	INTEGRAL	REDUIT	
SOUDE	52	50	FULL
BOULONNE	53	51	STELLITE

**OPTIONS :**

- \* CHAPEAU SOUDE
- \* RACCORDEMENT BRIDES ISO PN20 - 50 - 100 - 250 - 420

**NORMES :**

- \* API 602

PASSAGE REDUIT								
D	8	10	15	20	25	32	40	50
N	1/4	3/8	1/2	3/4	1	1 1/4	1 1/2	2
FAF			80	90	110	127	155	170
H			49	55	70	77	105	120
D			9	12.50	17.50	22.50	29	35
MASSE			1.10	2.60	3.60	5.50	8.40	11.80

PASSAGE INTEGRAL								
D	8	10	15	20	25	32	40	50
N	1/4	3/8	1/2	3/4	1	1 1/4	1 1/2	2
FAF	80	80	90	110	127	155	170	210
H	49	49	55	70	77	105	120	145
D	7	9	12.50	17.50	22.50	29	35	45
MASSE	1.10	1.10	1.10	2.60	3.60	5.50	8.40	11.80

SOUS RESERVE DE MODIFICATIONS

19 rue Albert Thomas 44600 SAINT NAZAIRE - FRANCE

TEL : 02.51.10.18.18 FAX : 02.51.10.18.19

www.societe-gmi.com

REV .05

PAGE E090