

PRO-DIRIS® CLAPET A BATTANT

FORGE

CHAPEAU BOULONNE

INOX

NPT / SW / BW

800LBS

97/23/CE Catégorie III

CORPS / BODY	INOX 316L
CHAPEAU / BONNET	INOX 316L
BATTANT / SWING	INOX 316L
SIEGE / SEAT	INOX 316L
JOINT / GASKET	SPIRALE INOX 316L +GRAPHITE

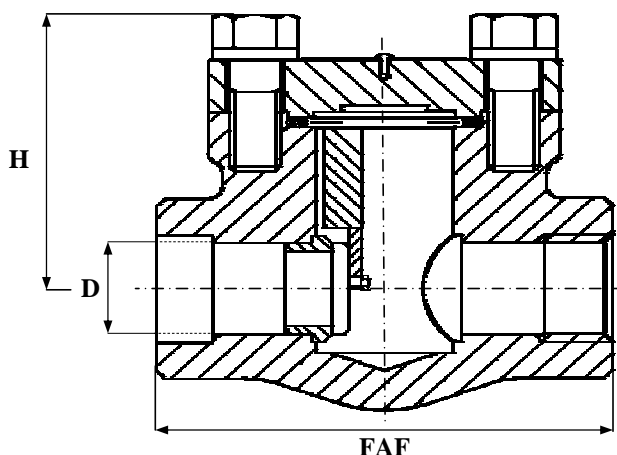

1 (1500 lbs)
237 8 (800 lbs) **50 (VOIR TABLEAU)**
 2 (2500 lbs)

CHAPEAU	PASSAGE		CONTACTS
	INTEGRAL	REDUIT	
SOUDE	52	50	FULL
BOULONNE	53	51	STELLITE

OPTIONS :

- * CHAPEAU SOUDE
- * RACCORDEMENT BRIDES ISO PN20 - 50 - 100 - 250 - 420

NORMES :

- * API 602

PASSAGE REDUIT								
D	N							
	8	10	15	20	25	32	40	50
	1/4	3/8	1/2	3/4	1	1 1/4	1 1/2	2
FAF			80	90	110		155	170
H			47	53	69		105	131
D			8	13	18		29	35
MASSE			1.20	1.40	2.50		6.30	9.10

PASSAGE INTEGRAL								
D	N							
	8	10	15	20	25	32	40	50
	1/4	3/8	1/2	3/4	1	1 1/4	1 1/2	2
FAF	80	80	90	110	127	155	170	210
H	47	47	53	69	85	105	131	150
D	8	8	13	18	22.5	29	35	46
MASSE	1.20	1.20	1.40	2.50	2.80	6.30	9.10	14.50

SOUS RESERVE DE MODIFICATIONS

19 rue Albert Thomas 44600 SAINT NAZAIRE - FRANCE

TEL : 02.51.10.18.18 FAX : 02.51.10.18.19

www.societe-gmi.com

REV .05

PAGE E130