

DUO-DIRIS® CLAPET A BATTANT

SANDWICH

DOUBLE BATTANT

ACIER

BRIDES

ISO PN25

97/23/CE Catégorie II

CORPS / BODY ACIER CARBONE

BATTANTS / DISCS INOX 316

RESSORT / SPRING INOX 316

SIEGE / SEAT NITRILE

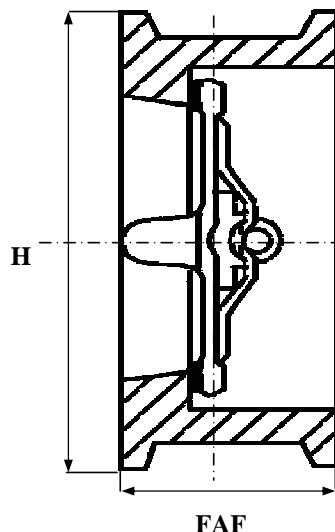

TEMPERATURE MAXI SERVICE 180°C

PRESSION MAXI DE SERVICE 25B

REF : 215 010

LE RAPPORT PRESSION/TEMPERATURE EST A DEFINIR PAR NOS SOINS

OPTIONS :

* CORPS ACIER / CUPRO ALU - REF 215 009

NORMES :

* NFE 29377

SOUS RESERVE DE MODIFICATIONS

D	8	10	15	20	25	32	40	50	65	80	100	125	150	200	250	300	350	400	500	600	
N	1/4	3/8	1/2	3/4	1	1 1/4	1 1/2	2	2 1/2	3	4	5	6	8	10	12	14	16	20	24	
FAF								54	54	57	64	70	76	95							
H								109	129	144	164	196	226	286							
MASSE								2.7	3.5	3.7	6.4	9.2	11.7	19.1							