

DUO-DIRIS® CLAPET A BATTANT

SANDWICH

DOUBLE BATTANT

INOX

BRIDES

ISO PN25

97/23/CE Catégorie II

CORPS /
BODY

INOX 316

BATTANTS /
DISCS

INOX 316

RESSORT /
SPRING

INOX 316

SIEGE /
SEAT

VITON

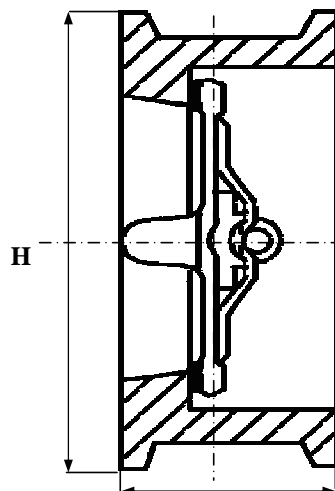

FAF

TEMPERATURE MAXI SERVICE 180°C

PRESSION MAXI DE SERVICE 25B

LE RAPPORT PRESSION/TEMPERATURE
EST A DEFINIR PAR NOS SOINS

REF : 215 008

NORMES :

* NFE 29377

SOUS RESERVE DE MODIFICATIONS

D	8	10	15	20	25	32	40	50	65	80	100	125	150	200	250	300	350	400	500	600
N	1/4	3/8	1/2	3/4	1	1 1/4	1 1/2	2	2 1/2	3	4	5	6	8	10	12	14	16	20	24
FAF								54	54	57	64	70	76	95	108	144				
H								109	129	144	170	196	226	285	342	402				
MASSE								2.7	3.5	3.7	6.4	9.2	11.7	19.1	25	36				