

## DUO-DIRIS® CLAPET A BATTANT

SANDWICH  
WAFER  
DOUBLE BATTANT

**ACIER - INOX**  
BRIDES  
ISO PN20 - 50 - 100 - 150 - 250 - 420  
97/23/CE Catégorie III  
ATEX

	<u>REF 215 030</u>	<u>REF 215 035</u>
CORPS / BODY	ACIER ZINGUE	INOX 316
BATTANT / DISC	INOX 316	INOX 316
RESSORT / SPRING	INOX 316	INOX 316
ETANCHEITE / BODY SEALS	INOX 316	INOX 316

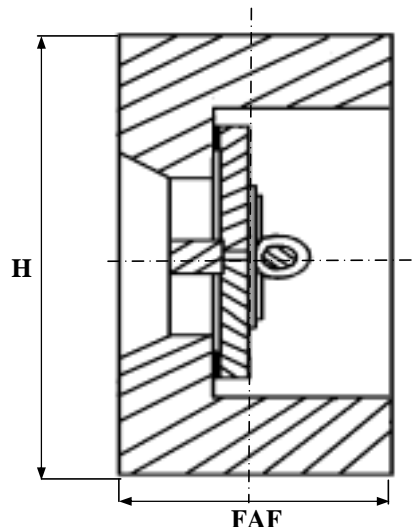

### NORMES :

- \* API 594
- \* SECURITE FEU API

### OPTIONS :

- \* VERSION RTJ
- \* ETANCHEITE PAR UN JOINT

D	8	10	15	20	25	32	40	50	65	80	100	125	150	200	250	300	350	400	450	500	600	
N	1/4	3/8	1/2	3/4	1	1 1/4	1 1/2	2	2 1/2	3	4	5	6	8	10	12	14	16	18	20	24	
<b>FAF PN20</b>								60	67	73	73	86	99	127	146	181	184	191				
<b>FAF PN50</b>								60	67	73	73	86	99	127	146	181	223	232				
<b>FAF PN100</b>								60	67	73	79	105	137	165	213	229	273	305				
<b>H PN20</b>								105	124	137	175	196	220	278	337	407	448	512				
<b>H PN50</b>								111	129	148	180	215	248	305	360	420	484	538				
<b>H PN100</b>								111	129	148	191	239	264	318	398	455	490	562				
<b>MASSE</b>	ISO PN20							2.7	4.6	5.5	7.5	11.5	15.5	30.5	48	75	90	120				
	ISO PN50							2.7	4.6	6	8	15	19	35	55	87	140	180				
	ISO PN100							2.7	4.7	7	11.5	23	35	58	105	145	195	275				

SOUS RESERVE DE MODIFICATIONS