

DIRIS® CLAPET A BATTANT

SANDWICH

SIMPLE BATTANT

ACIER
BRIDES

ISO PN10 - 16 - 20 - 25 - 40 - 50 - 100

	<u>REF 215 003</u>	<u>REF 215 013</u>
CORPS / BODY	ACIER ZINGUE	ACIER ZINGUE
BATTANT / DISC	ACIER ZINGUE	ACIER ZINGUE
ETANCHEITE / BODY SEALS	NITRILE	INOX 304
CROCHET / HOOK	ACIER	ACIER

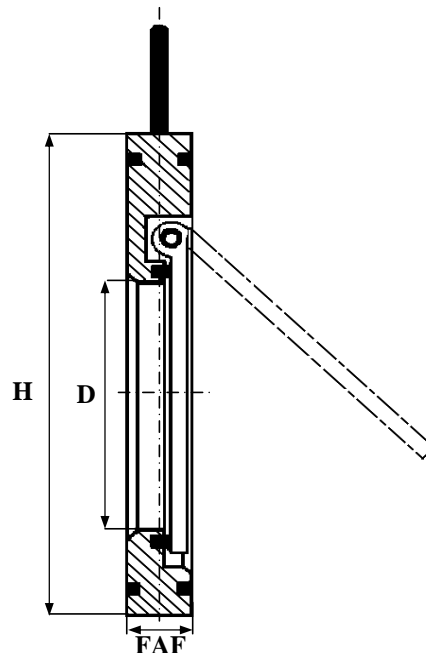

OPTIONS :

- * BATTANT INOX 304 OU 316
- * JOINT VITON OU PTFE
- * BUTEE D'OUVERTURE
- * JOINTS DE BRIDES AMONT AVAL

NORMES :

* NFE 29377

D	8	10	15	20	25	32	40	50	65	80	100	125	150	200	250	300	350	400	450	500	600
N	1/4	3/8	1/2	3/4	1	1 1/4	1 1/2	2	2 1/2	3	4	5	6	8	10	12	14	16	18	20	24
FAF PN10 / 16 / 20 / 25							16	16	16	16	16	16	19	28	32	38	38	48	48	58	68
FAF PN40							22	22	22	22	22	23	24	30	39	53	53	53	77	86	110
FAF PN50							22	22	22	22	24	26	26	33	52	58	66	66	85	92	125
FAF PN100							22	22	22	22	24	28	30	39	58	63					
H PN10							94	109	129	144	164	194	220	275	330	380	440	491	541	596	698
H PN16							94	109	129	144	164	194	220	276	331	386	446	497	558	620	737
H PN20							84	105	124	137	175	196	220	278	337	407	448	512	547	604	716
H PN25							94	109	129	144	170	196	226	286	344	404	460	517	567	627	734
H PN40							94	109	129	148	170	196	226	294	356	420	477	549	574	631	750
H PN50							94	112	129	148	180	215	250	305	360	420	484	538	595	652	773
H PN100							94	112	129	148	191	239	264	318	398	455					
D							19	26	38	46	72	96	114	140	188	216	263	305	356	407	482
MASSE	ISO PN10 - PN16 - PN20 - PN25						0.80	1	1.30	1.70	2.1	3.20	4.90	9	17	29	40	62	80	115	190
	ISO PN40						1	1.20	1.70	2.20	2.6	3.6	5.4	10.8	25	35	66	72	134	178	320
	ISO PN50						1	1.3	1.7	2.3	3,5	6.3	8.5	17.5	35	41	86	95	164	203	360
	ISO PN100						1	1.30	1.70	2.30	3.6	8	9.5	22	50	70					

SOUS RESERVE DE MODIFICATIONS

19 rue Albert Thomas 44600 SAINT NAZAIRE - FRANCE

TEL : 02.51.10.18.18 FAX : 02.51.10.18.19

www.societe-gmi.com

REV .05

PAGE E280