

DIRIS® CLAPET A BATTANT

CORPS AVEC TIRANTS
SECURITE FEU
SIMPLE BATTANT

ACIER

BRIDES
ISO PN20 - 50 - 100
97/23/CE Catégorie III

CORPS / BODY	ACIER XC38
BATTANT / DISC	INOX 316
ETANCHEITE / BODY SEALS	GRAPHITE / VITON

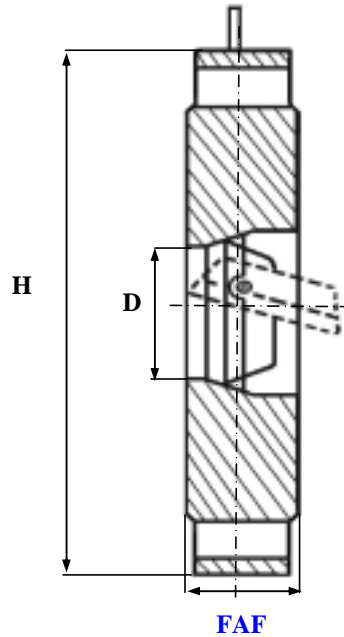

LE RAPPORT PRESSION/TEMPERATURE EST A DEFINIR PAR NOS SOINS

REF : 215 070

NORMES :

- * API 594
- * SECURITE FEU BS 6755

OPTIONS :

- * SECURITE FEU API 607
- * VERSION RTJ

D	N																				
	8	10	15	20	25	32	40	50	65	80	100	125	150	200	250	300	350	400	450	500	600
FAF PN20							42	42		45	50		60	65	65	72	100	100	110	135	155
FAF PN50							42	42		45	50		60	65	65	72	100	100	110	135	155
FAF PN100							42	42		45	50		60	65	65	72	100	100	110	135	155
H PN20							127	150		190	229		279	343	406	483	533	597	635	698	813
H PN50							156	165		210	254		318	381	444	521	584	648	711	775	914
H PN100							156	165		210	273		356	419	508	559	603	686	743	813	940
D							38	46		72	90		126	152	214	260	280	339	366	412	467
MASSE	ISO PN20						4	4.5		9	14		24	39	55	88	145	186	250	370	500
	ISO PN50						4.5	6		10	17		35	51	72	110	183	210	310	440	660
	ISO PN100						4.5	6		10	21		42	68	97	140	205	270	318	490	710

SOUS RESERVE DE MODIFICATIONS