

DINO-DIRIS® CLAPET A BATTANT

METAL / METAL

FONTE
BRIDES
ISO PN16

CORPS / BODY	FONTE GG 25
CHAPEAU / BONNET	FONTE GG 25
BATTANT / DISC	FONTE GG 25
SIEGES / SEATS	LAITON / LAITON
JOINT / GASKET	PLAT CSA 50

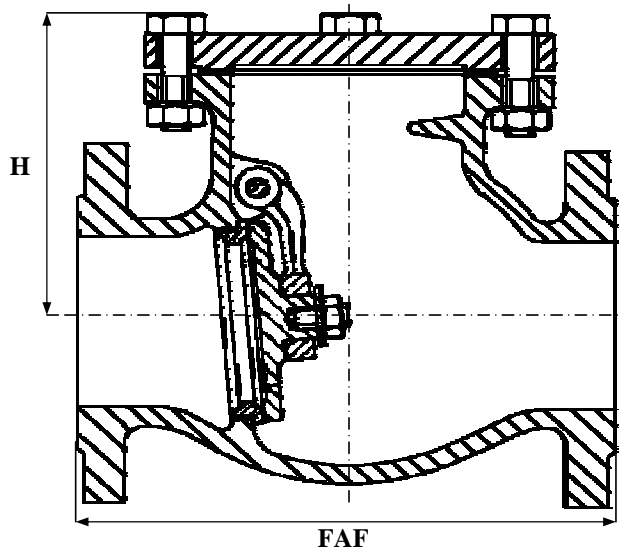

TEMPERATURE MAXI SERVICE 120°C*

PRESSION MAXI DE SERVICE 16B

LE RAPPORT PRESSION/TEMPERATURE
EST A DEFINIR PAR NOS SOINS

* (80° POUR ETANCHEITE CAOUTCHOUC)

REF : 220 100

OPTIONS :

* ETANCHEITE METAL / CAOUTCHOUC - REF : 220 101

NORMES :

* DIN 3202 F6

D	8	10	15	20	25	32	40	50	65	80	100	125	150	200	250	300	350	400	500	600
N	1/4	3/8	1/2	3/4	1	1 1/4	1 1/2	2	2 1/2	3	4	5	6	8	10	12	14	16	20	24
FAF							180	200	240	260	300	350	400	500	600	700	800	900		
H							120	135	150	170	190	200	220	265	310	315	380	415		
MASSE							12	15	20	30	40	69	73	105	113	150	260	315		

19 rue Albert Thomas 44600 SAINT NAZAIRE - FRANCE

TEL : 02.51.10.18.18 FAX : 02.51.10.18.19

www.societe-gmi.com

REV .05

PAGE E330