

DINO-DIRIS® CLAPET A BATTANT

METAL / METAL

ACIER
BRIDES
ISO PN16

CORPS / BODY	ACIER GSC 25
CHAPEAU / BONNET	ACIER GSC 25
BATTANT / DISC	ACIER GSC 25
SIEGES / SEATS	INOX F6
JOINT / GASKET	PLAT CSA 50

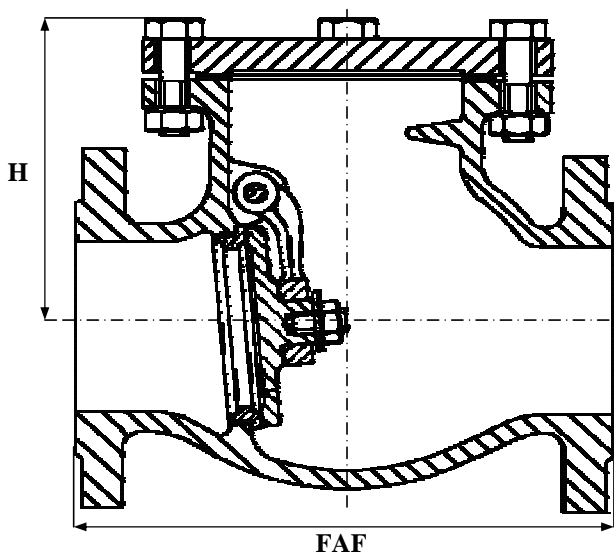

TEMPERATURE MAXI SERVICE 300°C

PRESSION MAXI DE SERVICE 16B

REF : 220 104

LE RAPPORT PRESSION/TEMPERATURE EST A DEFINIR PAR NOS SOINS

NORMES :

* DIN 3202 F6

D	8	10	15	20	25	32	40	50	65	80	100	125	150	200	250	300	350	400	500	600
N	1/4	3/8	1/2	3/4	1	1 1/4	1 1/2	2	2 1/2	3	4	5	6	8	10	12	14	16	20	24
FAF							180	200	240	260	300	350	400	500	600	700	800	900	1100	1300
H							125	125	150	160	165	230	270	355	395	470	520	600	670	760
MASSE							14	16	25	30	44	68	85	115	180	270	380	510	967	1507

19 rue Albert Thomas 44600 SAINT NAZAIRE - FRANCE

TEL : 02.51.10.18.18 FAX : 02.51.10.18.19

www.societe-gmi.com

REV .05

PAGE E340