

## DINO-DIRIS® CLAPET A BATTANT

METAL / METAL

**ACIER**  
BRIDES  
ISO PN25

CORPS / BODY	ACIER GSC 25
CHAPEAU / BONNET	ACIER GSC 25
BATTANT / DISC	ACIER GSC 25
SIEGES / SEATS	INOX F6
JOINT / GASKET	PLAT CSA 50

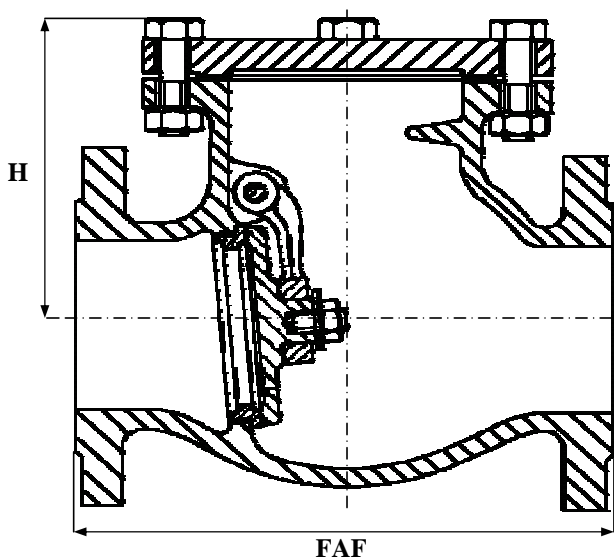

TEMPERATURE MAXI SERVICE 400°C

PRESSION MAXI DE SERVICE 25B

**REF : 220 102**

LE RAPPORT PRESSION/TEMPERATURE  
EST A DEFINIR PAR NOS SOINS

**NORMES :**

\* DIN 3202 F1

D	8	10	15	20	25	32	40	50	65	80	100	125	150	200	250	300	350	400	500	600
N	1/4	3/8	1/2	3/4	1	1 1/4	1 1/2	2	2 1/2	3	4	5	6	8	10	12	14	16	20	24
FAF								230	290	310	350	400	480	600	730	850	980	1100	1250	1450
H								125	150	160	165	230	270	355	395	470	520	600	670	760
MASSE								17	30	34	48	105	118	160	230	420	535	585	1025	1650

SOUS RESERVE DE

19 rue Albert Thomas 44600 SAINT NAZAIRE - FRANCE

TEL : 02.51.10.18.18 FAX : 02.51.10.18.19

www.societe-gmi.com

REV .05

PAGE E350