

DINO-DIRIS® CLAPET A BATTANT

METAL / METAL

ACIER
BRIDES
ISO PN40

CORPS / BODY	ACIER GSC 25
CHAPEAU / BONNET	ACIER GSC 25
BATTANT / DISC	ACIER GSC 25
SIEGES / SEATS	INOX F6
JOINT / GASKET	GRAPHITE

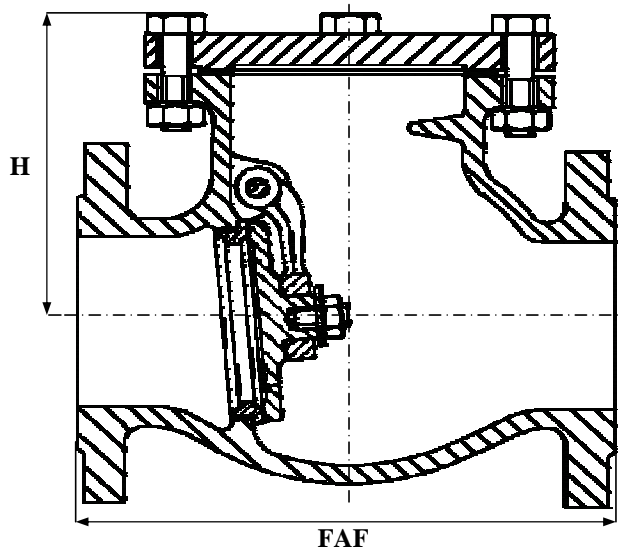

TEMPERATURE MAXI SERVICE 400°C

PRESSION MAXI DE SERVICE 40B

REF : 220 103

LE RAPPORT PRESSION/TEMPERATURE
EST A DEFINIR PAR NOS SOINS

NORMES :

* DIN 3202 F1

D	8	10	15	20	25	32	40	50	65	80	100	125	150	200	250	300	350	400	500	600
N	1/4	3/8	1/2	3/4	1	1 1/4	1 1/2	2	2 1/2	3	4	5	6	8	10	12	14	16	20	24
FAF							200	230	290	310	350	400	480	600	730	850	980	1100	1250	1450
							125	125	150	160	165	230	270	355	395	470	520	600	670	760
H																				
MASSE							15	17	30	34	48	105	118	220	320	450	600	800	1270	1800

19 rue Albert Thomas 44600 SAINT NAZAIRE - FRANCE

TEL : 02.51.10.18.18 FAX : 02.51.10.18.19

www.societe-gmi.com

REV .05

PAGE E360