

DINO-DIRIS® CLAPET A BATTANT

INOX
BRIDES
ISO PN16

97/23/CE Catégorie III

CORPS / BODY	INOX 316
CHAPEAU / BONNET	INOX 316
BATTANT / DISC	INOX 316
SIEGES / SEATS	INOX 316

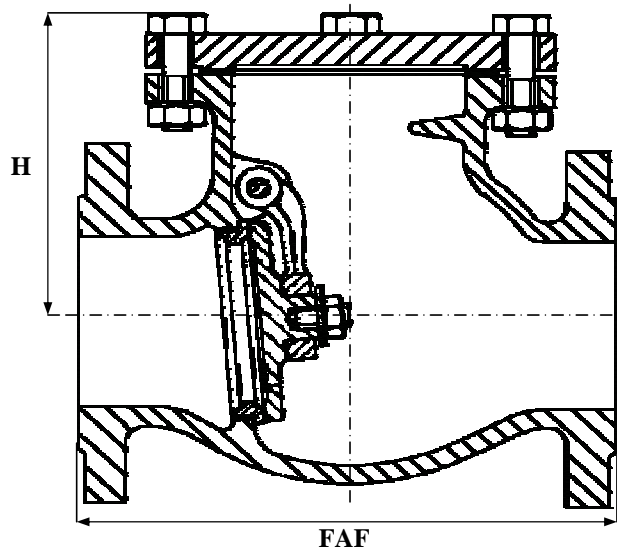

TEMPERATURE MAXI SERVICE 300°C

PRESSION MAXI DE SERVICE 16B

LE RAPPORT PRESSION/TEMPERATURE
EST A DEFINIR PAR NOS SOINS

REF : 220 105

NORMES :

* DIN 3202 F6

D	8	10	15	20	25	32	40	50	65	80	100	125	150	200	250	300	350	400	500	600		
N	1/4	3/8	1/2	3/4	1	1 1/4	1 1/2	2	2 1/2	3	4	5	6	8	10	12	14	16	20	24		
FAF							180	200	240	260	300	350	400	500								
	H						120	135	150	170	190	200	220	265								
MASSE							12	15	20	30	40	69	73	105								