

DINO-DIRIS® CLAPET A BATTANT

SERIE PETROLE

INOX
BRIDES RF
ISO PN20 - PN50 - PN100
97/23/CE Catégorie III

CORPS / BODY	INOX 351 CF8M (316)
COUVERCLE / COVER	INOX 351 CF8M (316)
BATTANT / DISC	INOX 351 CF8M (316)
SIEGE / SEAT	INOX 316
JOINT DE CORPS/ GASKET	GRAPHITE OU SPIRALE

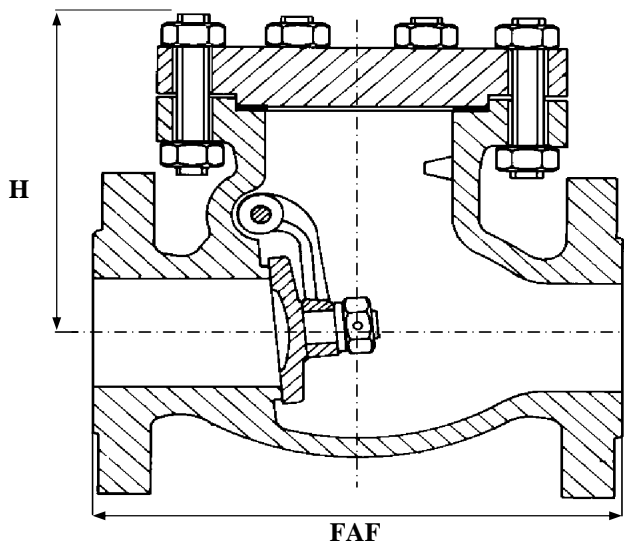

NORMES :

- * API 600 - API 598
- * ANSI B 16.10 - ANSI B 16.34

OPTIONS :

- * PORTEE STELLITEE

	D	50	65	80	100	150	200	250	300	350	400	450	500	600
		N	2	2 1/2	3	4	6	8	10	12	14	16	18	20
240 025	FAF	203		241	292	356	495	622	699	787	864			
	H	165		180	210	265	320	355	410	430	500			
	MASSE	17		33	47	86	150	230	340	440	550			
240 055	FAF	267		318	356	445	559	622	711					
	H	180		210	230	295	340	385	440					
	MASSE	27		50	68	146	240	350	495					
240 105	FAF	292		356	432	559	584	787	711					
	H	187		231	295	362	420	480	545					
	MASSE	34		665	88	220	405	620	820					

SOUS RESERVE DE MODIFICATIONS