

COMPENSATEUR DE DILATATION

SOUPLE

DOUBLE ONDE

EPDM

BRIDES ACIER

ISO PN16

CORPS /
BODY EPDM+RENFORT
NYLON

BRIDES /
FLANGES ACIER A 24

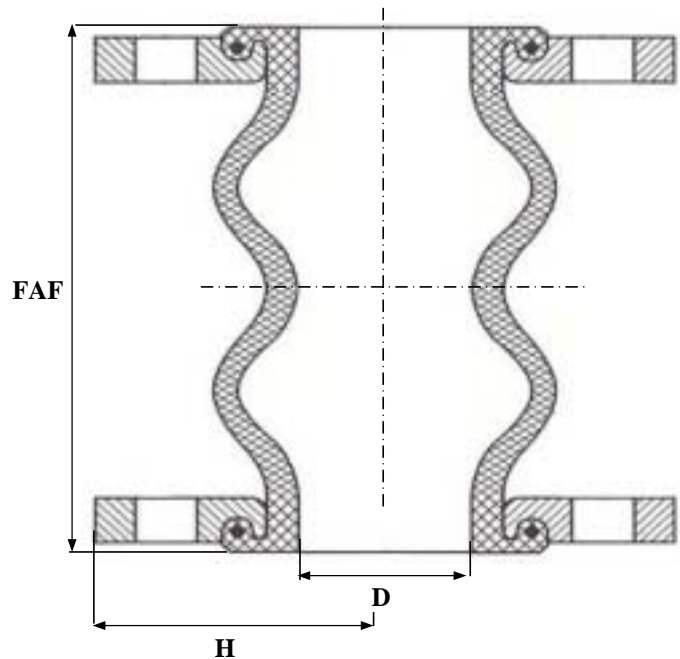

TEMPERATURE MAXI SERVICE 100°C

REF : 290 102

PRESSION MAXI DE SERVICE 16B

LE RAPPORT PRESSION/TEMPERATURE
EST A DEFINIR PAR NOS SOINS

OPTION :

PERCAGES DES BRIDES ANSI 150LBS

SOUS RESERVE DE MODIFICATIONS

D	10	15	20	25	32	40	50	65	80	100	125	150	200	250	300	350	400	450	500	600	
N	3/8	1/2	3/4	1	1 1/4	1 1/2	2	2 1/2	3	4	5	6	8	10	12	14	16	18	20	24	
FAF						175	175	175	175	225	225	225	325	325	325						
FAF Minimum						125	125	125	125	175	175	175	265	265	265						
FAF Maximum						205	205	205	205	260	260	260	360	360	360						
Transversal +/-						45	45	45	45	40	40	40	35	35	35						
D						40	52	68	76	103	128	152	195	250	300						
MASSE						3.10	4.10	6	6.50	9.20	11.1	13.4	20	29	43						

19 rue Albert Thomas 44600 SAINT NAZAIRE - FRANCE

TEL : 02.51.10.18.18 FAX : 02.51.10.18.19

www.societe-gmi.com

REV .05

PAGE F210