

## HUBLOT A MANCHON

DIN 11851

**INOX**  
A SOUDER  
PN6

ECROU CANNELE / SLOTTED COVER NUT	INOX 316L
JOINT PLAT / FLAT GASKET	PTFE
VERRE / SIGHTGLASS DISC	SILICATE <sup>(1)</sup>
JOINT TORIQUE / RING SEAL	VITON / PTFE / EPDM / PERBUNAN
MANCH. A SOUDER / WELD NECK NOZZLE	INOX 316L

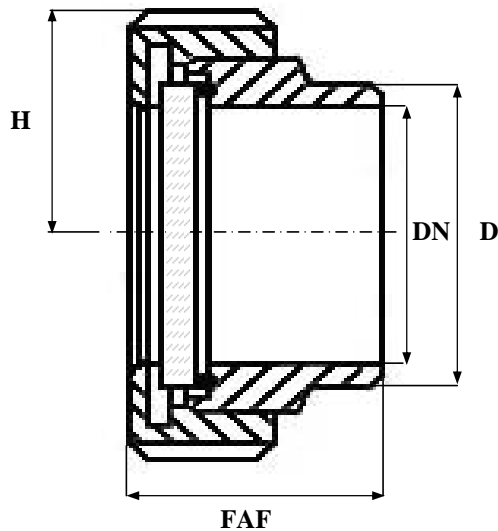

(1) SILICATE DE SOUDE 150°C MAXI  
SILICATE DE BORE 280°C MAXI

TEMPERATURE MAXI SERVICE 280°C

**REF : 280 300**

PRESSION MAXI DE SERVICE 6B

LE RAPPORT PRESSION/TEMPERATURE  
EST A DEFINIR PAR NOS SOINS

SOUS RESERVE DE MODIFICATIONS

D	8	10	15	20	25	32	40	50	65	80	100	125	150	200	250	300	350	400	500	600	
N	1/4	3/8	1/2	3/4	1	1 1/4	1 1/2	2	2 1/2	3	4	5	6	8	10	12	14	16	20	24	
FAF							40	45	53	58	68	58									
H							39	46	56	63	74	89									
D							43	55	72	87	106	132									