

## HUBLOT A BRIDES

DIN 28120

**INOX**  
A SOUDER  
PN6 - 10 - 16

BRIDE A SOUDER / WELDING FLANGE	INOX 316L
VERRE / SIGHTGLASS DISC	SILICATE <sup>(1)</sup>
JOINT / SEAL	VITON / PTFE / EPDM / PERBUNAN
CONTRE BRIDE / COVER FLANGE	INOX 316L

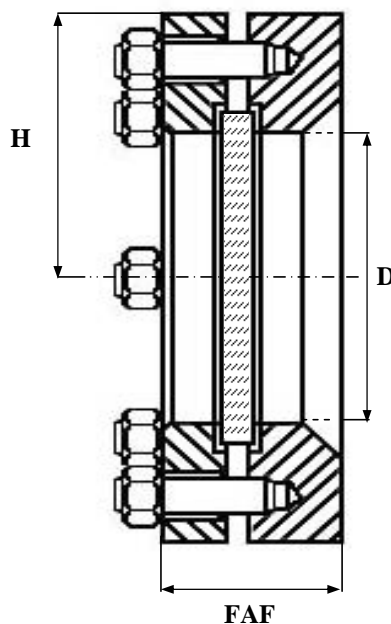

(1) SILICATE DE SOUDE 150°C MAXI  
SILICATE DE BORE 280°C MAXI

TEMPERATURE MAXI SERVICE 280°C

**REF : 280 301**

PRESSION MAXI DE SERVICE 16B

LE RAPPORT PRESSION/TEMPERATURE  
EST A DEFINIR PAR NOS SOINS

**OPTIONS :**

- \* BRIDES ACIER - UB6 - OU AUTRES
- \* PROJECTEUR
- \* GRILLE DE PROTECTION

SOUS RESERVE DE MODIFICATIONS

D	8	10	15	20	25	32	40	50	65	80	100	125	150	200	250	300	350	400	500	600
N	1/4	3/8	1/2	3/4	1	1 1/4	1 1/2	2	2 1/2	3	4	5	6	8	10	12	14	16	20	24
FAF					42		49	52		61	68	71	87	92	79	66				
H					57.5		75	82.5		100	110	125	142.5	170	197.5	222.5				
D					48		65	80		100	125	150	175	225	275	325				
PN					16		16	16		16	16	16	16	10	6	6				