

RESPI-SPIRALIS® SOUPAPE PRESSION

ALUMINIUM
ECHAPPEMENT LIBRE
ATEX II 2 G 2B

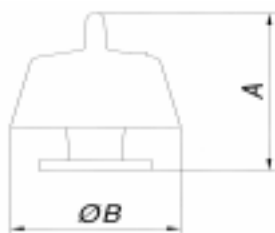

DETAILS DU CLAPET

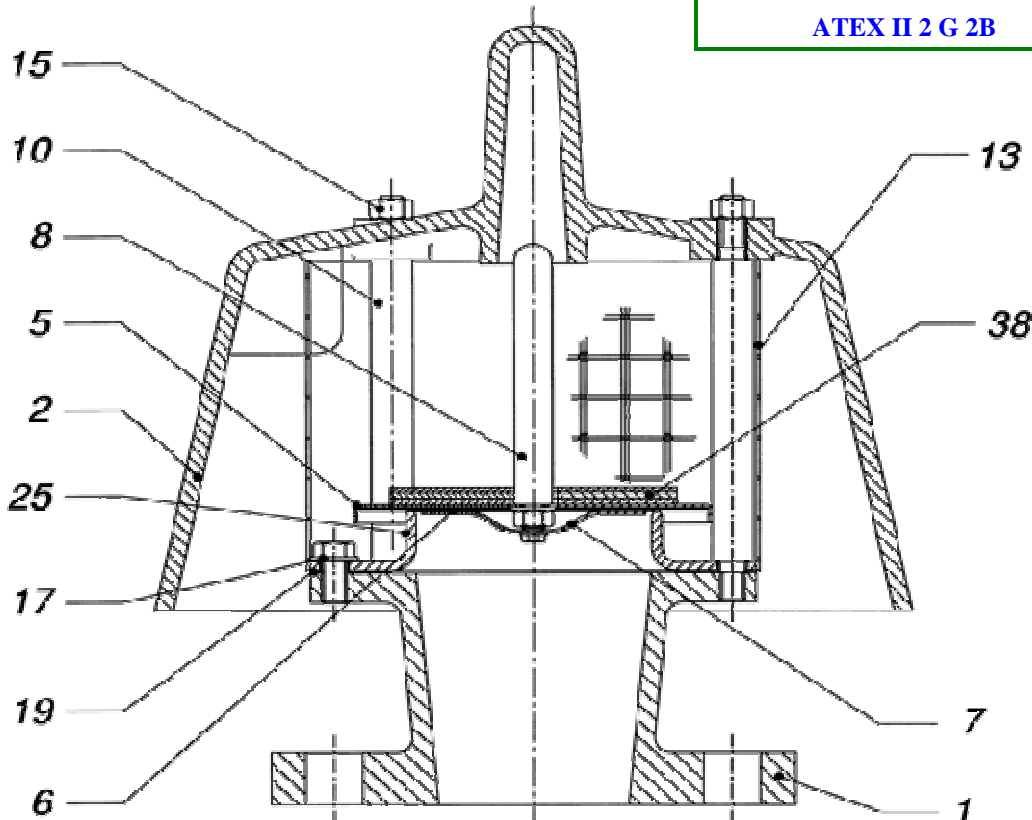
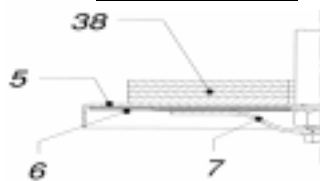

D	50	80	100	150	200	250	300
N	2	3	4	6	8	10	12
A	250	310	365	448	500	560	600
B	230	250	325	408	485	578	652
MASSE							

REF : 251 053

GRILLE DE DEBIT PAGE X220

N°	DESIGNATION - DESCRIPTION	MATIERES - MATERIALS	N°	DESIGNATION - DESCRIPTION	MATIERES - MATERIALS
1	CORPS - BODY	ALUMINIUM	13	ECRAN - PRESSURE SCREEN	AISI 304
2	COUVERCLE - PRESSURE HOOD	ALUMINIUM	15	ECROU - HEXAGONAL NUT	AISI 304
5	CLAPET - PALLET	AISI 316	17	RONDELLE - WASHER	AISI 304
6	MEMBRANES - DIAPHRAGM	VITON	19	JOINT - GASKET	FLEXOID
7	DÉFLECTEUR - DEFLECTOR	AISI 316	25	SIEGE - PRESSURE SEAT	AISI 316L
8	TIGE GUIDAGE - PRESSURE STEM	ALUMINIUM	38	TARAGE - LOADING WEIGHTS	AISI 304
10	GUIDAGE - PRESSURE GUIDE	AISI 304			

SOUS RESERVE DE MODIFICATIONS