

RESPI-SPIRALIS® SOUPAPE PRESSION / DEPRESSION

ALUMINIUM
ECHAPPEMENT CANALISE
ATEX II 2 G 2B

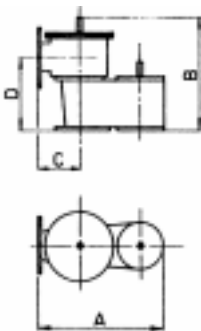

DETAIL du CLAPET

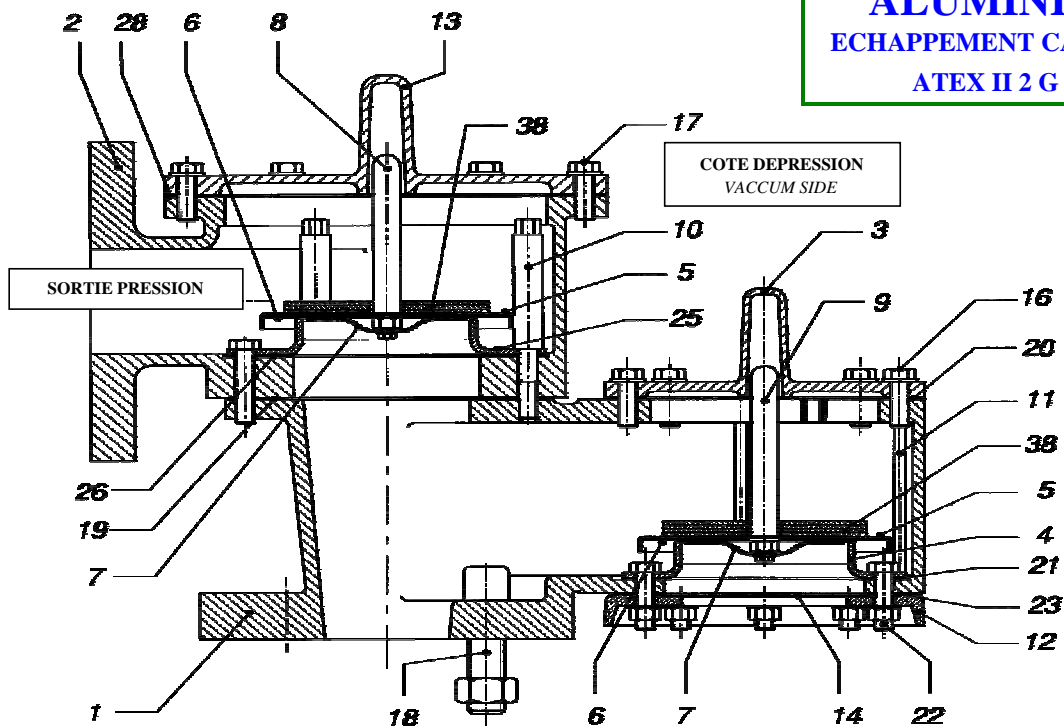
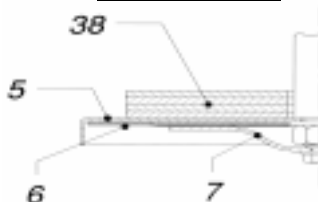

D	50	80	100	150	200	250	300
N	2	3	4	6	8	10	12
A	360	415	470	625	745	875	993
B	290	352	416	520	632	773	900
C	130	145	160	220	250	290	320
D	177	200	231	280	348	417	512
MASSE							

REF : 251 092

GRILLE DE DEBIT PAGE X230

SOUS RESERVE DE MODIFICATIONS

N°	DESIGNATION - DESCRIPTION	MATIERES - MATERIALS	N°	DESIGNATION - DESCRIPTION	MATIERES - MATERIALS
1	CORPS - BODY	ALUMINIUM	14	ECRAN DEPRESSION - VACUUM SCREEN	AISI 304
2	BRIDE SORTIE - PRESSURE CONVEYOR	ALUMINIUM	15	ECROU - HEXAGONAL NUT	AISI 304
3	CAPOT - HOOD	ALUMINIUM	16	GOUJON - STUD BOLT	AISI 304
4	SIEGE - SEAT	AISI 316L	17	RONDELLE - WASHER	AISI 304
5	CLAPET - PALLET	AISI 316L	18	GOUJON - STUD BOLT	AISI 304
6	MEMBRANES - DIAPHRAM	PTFE / FEP	19	JOINT - GASKET	FLEXOID
7	DEFLECTEUR - DEFLECTOR	AISI 316	20	JOINT - GASKET	FLEXOID
8	TIGE GUIDAGE PRES - PRESSURE STEM	ALUMINIUM	21	JOINT - GASKET	FLEXOID
9	TIGE GUIDAGE DEPRES - VACUUM STEM	ALUMINIUM	22	VIS - SCREW	AISI 304
10	GUIDAGE PRESSION - PRESSURE GUIDE	AISI 304	25	SIEGE PRESSION - PRESSURE SEAT	AISI 316L
11	GUIDAGE DEPRESSION - VACUUM GUIDE	AISI 304	26	JOINT - GASKET	FLEXOID
12	GOUTTE D'EAU - WATER DRIP	ALUMINIUM	28	JOINT - GASKET	FLEXOID
13	CAPOT PRESSION - PRESSURE HOOD	ALUMINIUM	38	TARAGE - LOADING WEIGHTS	AISI 304