

DISCO-SPIRALIS® DISQUE DE RUPTURE

DISQUE REVERSE
NON FRAGMENTANT
MONTAGE DANS MONTURES

DN25 à DN250

EQUIPE D'UN DETECTEUR RUPTURE

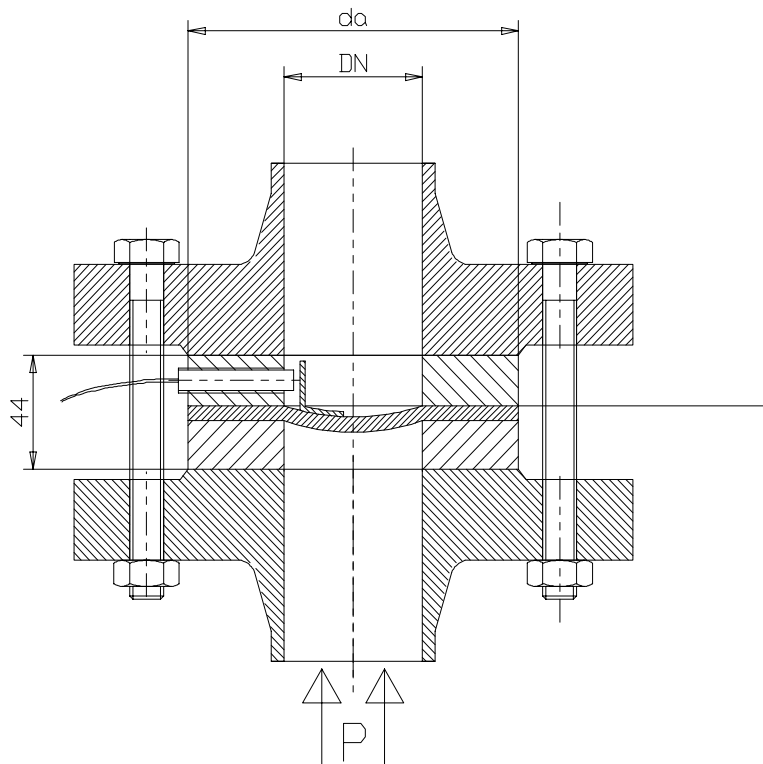

REF : 260 450

D	8	10	15	20	25	32	40	50	65	80	100	125	150	200	250	300	350	400	500	600	
N	1/4	3/8	1/2	3/4	1	1 1/4	1 1/2	2	2 1/2	3	4	5	6	8	10	12	14	16	20	24	
Da PN 10				70		90	102	124	140	160		212	270	312							
Da PN 16				70		90	102	124	140	160		212	260	312							
Da PN 20				66		83	90	94	124	140		212	270	320							
Da PN 25				70		90	102	124	140	160		212	270	335							
Da PN 40				70		90	102	124	140	160		212	270	335							
Da PN 50				66		82	90	94	124	140		212	270	335							
Da PN 100				66		82	90	94	124	140		212	270	335							
E				44		44	44	44	44	44		44	44	44							

SOUS RESERVE DE MODIFICATIONS

19 rue Albert Thomas 44600 SAINT NAZAIRE - FRANCE

TEL : 02.51.10.18.18 FAX : 02.51.10.18.19

www.societe-gmi.com

REV .05

PAGE G440